

TECHNICAL SPECIFICATION

Features :

- 60W rated power
- Compact Size
- LED Indicate For Power ON
- Din Rail Mount
- Cooling by free air convection

Protection Available :

- Overload
- Over Voltage
- Output short circuit
- Over Temperature

Input Specification :

Supply Voltage	100 to 270V AC±10%,(L-N)
Frequency Range	50 / 60Hz
AC Current (TYP.)	0.930A@100V AC, 0.470A@270V AC
Efficiency (TYP.)	>89%@230V AC
Start UP time	<1 sec@230V AC & <3 sec@100VAC (Full Load)

Output Specification :

Output Voltage	23 - 28V DC
Output Current	2.5A at 24; 2.1A at 28V
Ripple & noise	<1% of V out
Line & Load Regulation	±1%
Hold UP Time	<60ms at 230V AC & >15ms at 100V AC (Full Load)

Protection :

Input Fuse	3.15A-250V AC Internal
Output Over Load	110% to 120% of rated output Current protection Protection Type : hiccup mode; recover automatically after fault condition is removed
Output Short Circuit	Hiccup mode when output is shorted;Recovers automatically after fault condition is removed.
Output Over Voltage	SMPS Latches off if output voltage Exceeds the specified output voltage Limits.
Over Temperature	Power supply shuts down when the temperature goes above specified limit; Turns on automatically after temperature goes back to Normal operating conditions.
Isolation between Input and Output :	2.5 KV
Surge Protection :	Pulse 1.2/50µS Line To Neutral : 2 KV Line To Earth : 2 KV

Physical :

Mounting Type	Din Rail Mount
Size (H) x (W) x (D)	90 x 45 x 84
Material	PC

Environmental :

Working Temperature	-25 °C to 50 °C * De-rate output power at 3w/ °C above +50 °C Ambient
Storage Temperature	-40 °C to 85 °C
Relative Humidity	95% RH Non-condensing

MECHANICAL INSTALLATION

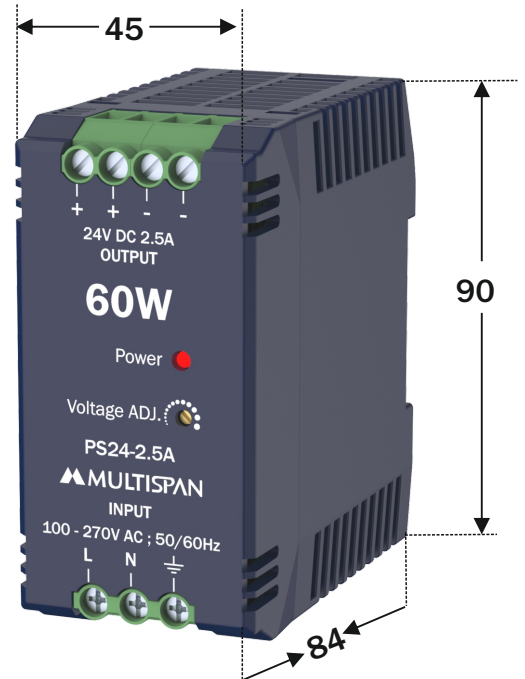



SAFETY PRECAUTION

All safety related codifications, symbols and instructions that appear in this operating manual or on the equipment must be strictly followed to ensure the safety of the operating personnel as well as the instrument.

If all the equipment is not handled in a manner specified by the manufacturer, it might impair the protection provided by the equipment.



Read complete instructions prior to installation and operation of the unit.



WARNING : Risk of electric shock.

WARNING GUIDELINES



WARNING : Risk of electric shock.

1. To prevent the risk of electric shock, power supply to the equipment must be kept OFF while doing the wiring arrangement. Do not touch the terminals while power is being supplied.
2. To reduce electro magnetic interference, use wire with adequate rating and twists of the same of equal size shall be made with shortest connection.
3. Cable used for connection to power source, must have a cross section of 1mm or greater. These wires should have insulations capacity made of at least 1.5kV.
4. When extending the thermocouple lead wires, always use thermocouple compensation wires for wiring for the RTD type, use a wiring material with a small lead resistance (5 Ω max per line) and no resistance differentials among three wires should be present.
5. A better anti-noise effect can be expected by using standard power supply cable for the instrument.

INSTALLATION GUIDELINES

1. This equipment, being built-in-type, normally becomes a part of main control panel and in such case the terminals do not remain accessible to the end user after installation and internal wiring.
2. Do not allow pieces of metal, wire clippings, or fine metallic fillings from installation to enter the product or else it may lead to a safety hazard that may in turn endanger life or cause electrical shock to the operator.
3. Circuit breaker or mains switch must be installed between power source and supply terminal to facilitate power 'ON' or 'OFF' function. However this mains switch or circuit breaker must be installed at convenient place normally accessible to the operator.
4. Use and store the instrument within the specified ambient temperature and humidity ranges as mentioned in this manual.

MECHANICAL INSTALLATION GUIDELINES

1. Prepare the panel cutout with proper dimensions as shown above.
2. Fit the unit into the panel with the help of clamp given.
3. The equipment in its installed state must not come in close proximity to any heating source, caustic vapors, oil steam, or other unwanted process Byproducts.
4. Use the specified size of crimp terminal (M3.5 screws) to wire the terminal block. Tightening the screws on the terminal block using the tightening torque of the range of 1.2 N.m.
5. Do not connect anything to unused terminals.

MAINTENANCE

1. The equipment should be cleaned regularly to avoid blockage of ventilating parts.
2. Clean the equipment with a clean soft cloth. Do not use isopropyl alcohol or any other cleaning agent.
3. Fusible resistor must not be replaced by operator.

Specifications are subject to change, since development is a continuous process,
So for more updated operating information and Support,
Please contact our Helpline: +91-9978991483/9978991481 or
Email at service@multispanindia.com Ver:2311



TECHNICAL SPECIFICATION

Features :

- 240W rated power
- LED Indicate For Power ON
- Din Rail Mount
- Cooling by free air convection

Protection Available :

- Overload
- Over Voltage
- Output short circuit
- Over Temperature

Input Specification :

Supply Voltage	100 to 270V AC (L-N)
Frequency Range	50 / 60Hz
Power Factor	> 0.95 @ Full Load
AC Current (TYP.)	2.7A@100V AC, 1.2A@230V AC
Efficiency (TYP.)	>93%@230V AC
Start UP time	<2 sec@230V AC (Full Load)

Output Specification :

Nominal DC Voltage	24V DC
Output Voltage	24 - 28V DC
Output Current	10A at 24; 8.57A at 28V
Ripple & noise (max)	<1% of V out
Line & Load Regulation	±1%
Hold UP Time	>13ms at 24V @ 100 /230V AC (Full Load)

Protection :

Input Fuse	4A-250V AC Internal
Output Over Load	110% to 140% of rated output Current protection Protection Type : hiccup mode; recover automatically after fault condition is removed
Output Short Circuit	Hiccup mode when output is shorted;Recovers automatically after fault condition is removed.
Output Over Voltage	SMPS Latches off if output voltage 31V DC ± 0.5V DC
Over Temperature	Power supply shuts down when the temperature goes above specified limit; Turns on automatically after temperature goes back to Normal operating conditions.

Physical :

Mounting Type	35mm Din Rail
Size (H) x (W) x (D)	125 x 55 x 135
Material	PC
Weight	625 gms

Function :

DC OK Signal
Contact closes @ 23.0V (typ.) Contact opens @ 22.5V (typ.)
Contact Rating : 30V DC 1A ; 60V DC 0.5A ; 125V AC 0.5A ; resistive load , min. current 1 mA

Environmental :

Working Temperature	-25 °C to 50 °C * De-rate output power at 3w/°C above +50 °C Ambient
Storage Temperature	-40 °C to 85 °C
Relative Humidity	95% RH Non-condensing

MECHANICAL INSTALLATION

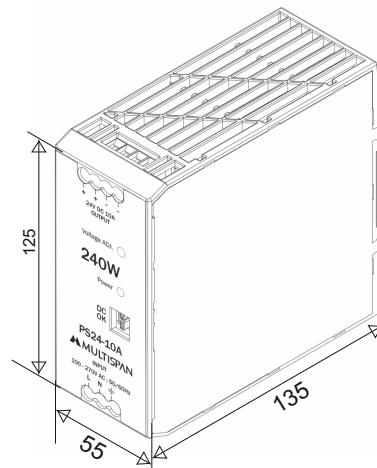



SAFETY PRECAUTION

All safety related codifications, symbols and instructions that appear in this operating manual or on the equipment must be strictly followed to ensure the safety of the operating personnel as well as the instrument.

If all the equipment is not handled in a manner specified by the manufacturer, it might impair the protection provided by the equipment.



Read complete instructions prior to installation and operation of the unit.



WARNING : Risk of electric shock.

WARNING GUIDELINES



WARNING : Risk of electric shock.

1. To prevent the risk of electric shock, power supply to the equipment must be kept OFF while doing the wiring arrangement. Do not touch the terminals while power is being supplied.
2. To reduce electro magnetic interference, use wire with adequate rating and twists of the same of equal size shall be made with shortest connection.
3. Cable used for connection to power source, must have a cross section of 1mm or greater. These wires should have insulations capacity made of at least 1.5kV.
4. When extending the thermocouple lead wires, always use thermocouple compensation wires for wiring for the RTD type, use a wiring material with a small lead resistance (5 Ω max per line) and no resistance differentials among three wires should be present.
5. A better anti-noise effect can be expected by using standard power supply cable for the instrument.

INSTALLATION GUIDELINES

1. This equipment, being built-in-type, normally becomes a part of main control panel and in such case the terminals do not remain accessible to the end user after installation and internal wiring.
2. Do not allow pieces of metal, wire clippings, or fine metallic fillings from installation to enter the product or else it may lead to a safety hazard that may in turn endanger life or cause electrical shock to the operator.
3. Circuit breaker or mains switch must be installed between power source and supply terminal to facilitate power 'ON' or 'OFF' function. However this mains switch or circuit breaker must be installed at convenient place normally accessible to the operator.
4. Use and store the instrument within the specified ambient temperature and humidity ranges as mentioned in this manual.

MECHANICAL INSTALLATION GUIDELINES

1. Prepare the panel cutout with proper dimensions as shown above.
2. Fit the unit into the panel with the help of clamp given.
3. The equipment in its installed state must not come in close proximity to any heating source, caustic vapors, oil steam, or other unwanted process Byproducts.
4. Use the specified size of crimp terminal (M3.5 screws) to wire the terminal block. Tightening the screws on the terminal block using the tightening torque of the range of 1.2 N.m.
5. Do not connect anything to unused terminals.

MAINTENANCE

1. The equipment should be cleaned regularly to avoid blockage of ventilating parts.
2. Clean the equipment with a clean soft cloth. Do not use isopropyl alcohol or any other cleaning agent.
3. Fusible resistor must not be replaced by operator.

Specifications are subject to change, since development is a continuous process, So for more updated operating information and Support, Please contact our Helpline: +91-9978991483/9978991481 or Email at service@multispanindia.com Ver:2102