

**MULTISPAN**

**3 Phase VAF Meter  
AVF-133-M1**



**TECHNICAL SPECIFICATION**

**FEATURES**

Separate display for Amp indication
Wiring System: 3Ø-4W, 3Ø-3W, 1Ø-2W
Load Hour , RPM, Phase sequence by LED indication

**INPUT**

Voltage AC	
Direct Voltage AC	30 to 300V (L - N) 50 to 520V (L - L)
Burden	< 0.2 VA
Current AC	
Primary CT Ratio	5 to 9999 Selectable
Secondary Current Ac	0.1 To 5 Amp
Burden	< 0.2 VA
Overload	Up to 6A Continuous
Frequency	45.0 to 65.0 HZ

**CALCULATED PARAMETERS**

Voltage	VLL , VLN , Avg
Current	All Phase Amp, Avg Amp
Frequency	System Frequency
Phase Sequence	Indication
Load Hour	Up to 9999 Hr 59 min

**ACCURACY**

Class 0.5 (Standard)
----------------------

**AUXILIARY POWER SUPPLY**

Power Supply	100 to 270V AC/DC, 50/60Hz
Burden	4VA

**DISPLAY, KEY & LED**

Display	3 Digit , 6 Line 7 Seg. 0.36" Red LED
Key	Scroll, Set, Inc , Dec
LED Indication	A , KA , VLL , VLN , Avg, PS, Hz

**ENVIRONMENTAL CONDITION**

Working Temperature	0 to 55 °C
Storage Temperature	0 to 55 °C
Relative Humidity	95 % RH Non - Condensing
Protection Level	IP-65 (Front side As per IS/IEC 60529 : 2001)

**DIMENSION**

Size (mm)	101 (H) x 101 (W) x 54 (D) mm
Panel Cutout	92 (H) x 92 (W) mm

**TERMINAL CONNECTION**

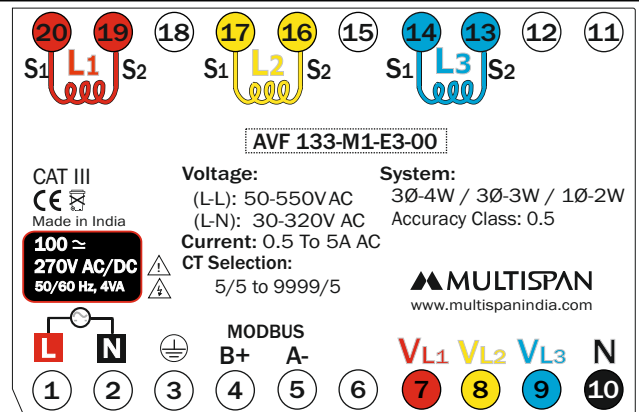

Please Refer page-2 for wiring connection

**KEY OPERATION**

FUNCTION	SYMBOL
To enter in parameter setting mode	SET + ^
<b>Operator mode:</b> To change page	^
<b>Parameter setting mode:</b> To increment value To decrement value in parameter setting mode.	^ v
To set the parameter value and to be save and exit from menu.	SET
Scroll & hold for 5 Sec	Scroll

NOTE :

1) If Phase sequence is not correct then PS LED will turn ON.

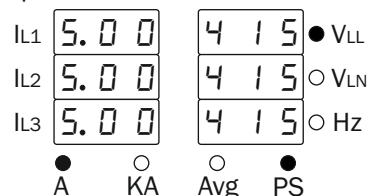

2) If Current exceed 999Amp, KA LED will turn ON. Display will be as show below.

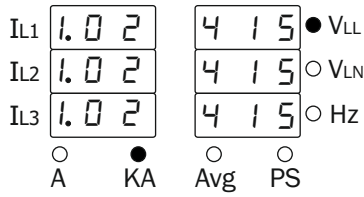

3) In Load hour page blinking LDH is indicating that load hour is incrementing.

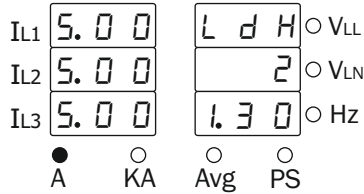

Actual load hour = 21 hours 30 minutes.

### PARAMETER SETTING

Press **SET** key & **^** key together for C.T ratio selection & network connection

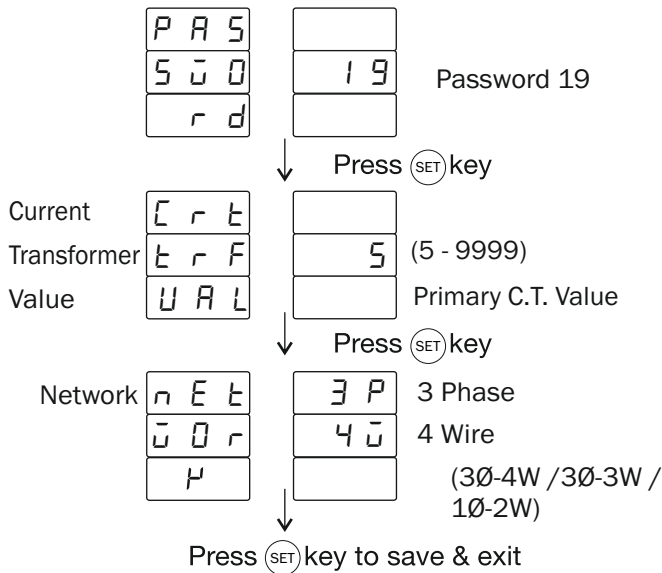

Press **SET** key & **^** key together for reset load hour

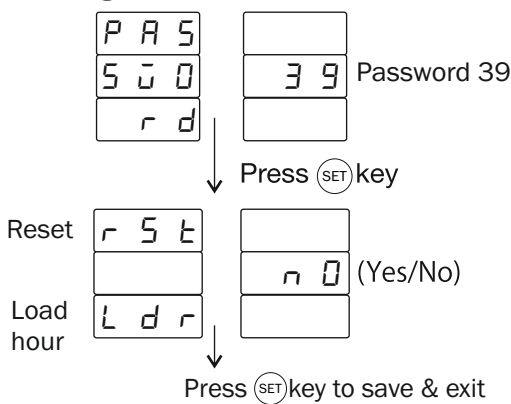

Press **SET** key & **^** key together for load hour & RPM.

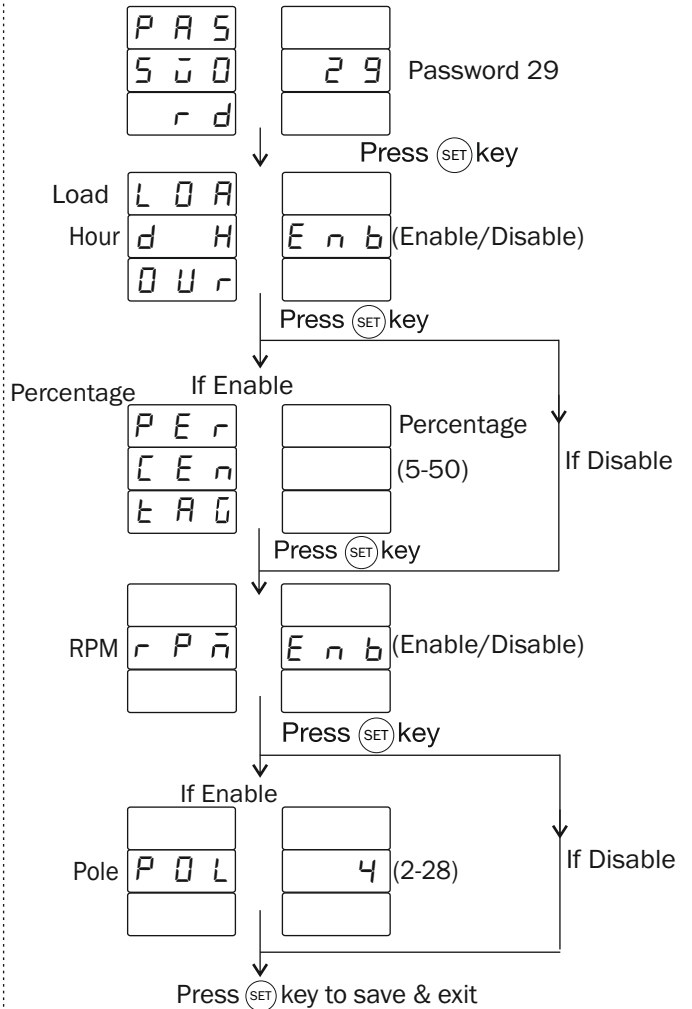

### 1Ø-2W NETWORK CONNECTION

1) Average Page :-

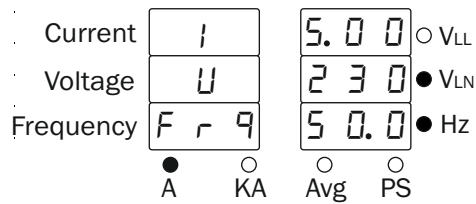

2) Load hour & RPM Page :-

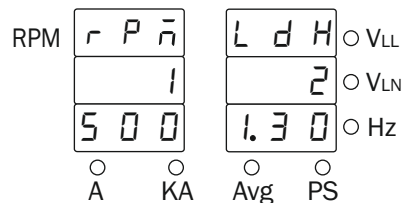

## 3Ø-4W NETWORK CONNECTION

### 1) VLL Page :-

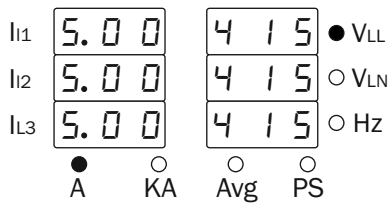

### 2) VLN Page :-

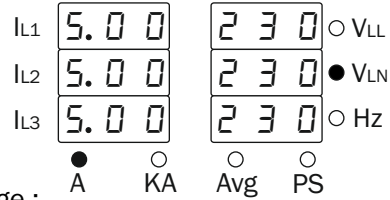

### 3) Frequency Page :-

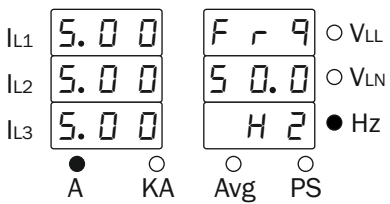

### 4) Average Page (VLN),(VLL),(AMP) :-

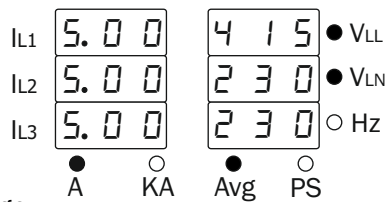

### 5) Load Hour Page :-

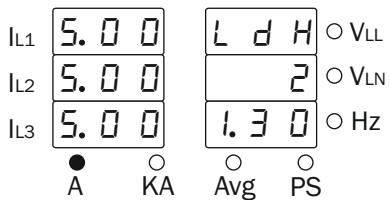

### 6) RPM Page:-

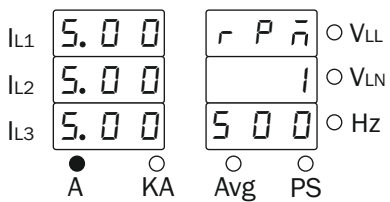

## 3Ø-3W NETWORK CONNECTION

### 1) VLL Page :-

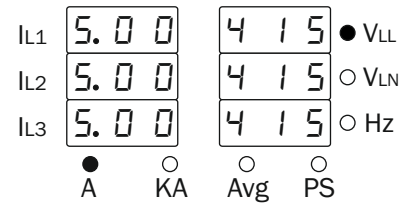

### 2) Frequency Page :-

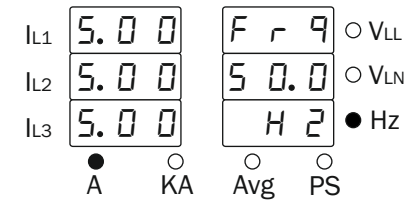

### 3) Average Page(VLL), (AMP) :-

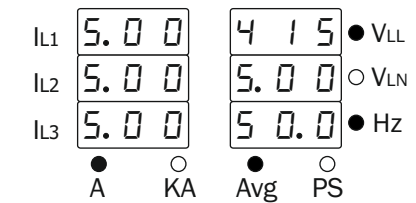

### 4) Load Hour page :-

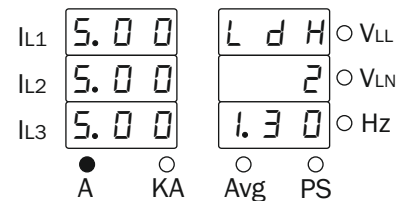

### 5) RPM Page:-

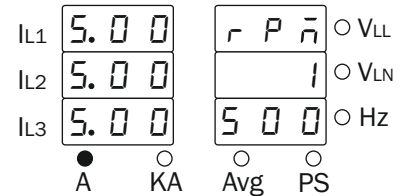

## INSTALLATION GUIDELINES

1. This equipment, being built-in-type, normally becomes a part of main control panel and in such case the terminals do not remain accessible to the end user after installation and internal wiring.
2. Do not allow pieces of metal, wire clippings, or fine metallic fillings from installation to enter the product or else it may lead to a safety hazard that may in turn endanger life or cause electrical shock to the operator.
3. Circuit breaker or mains switch must be installed between power source and supply terminal to facilitate power 'ON' or 'OFF' function. However this mains switch or circuit breaker must be installed at convenient place normally accessible to the operator.
4. Use and store the instrument within the specified ambient temperature and humidity ranges as mentioned in this manual.

## MECHANICAL INSTALLATION GUIDELINES

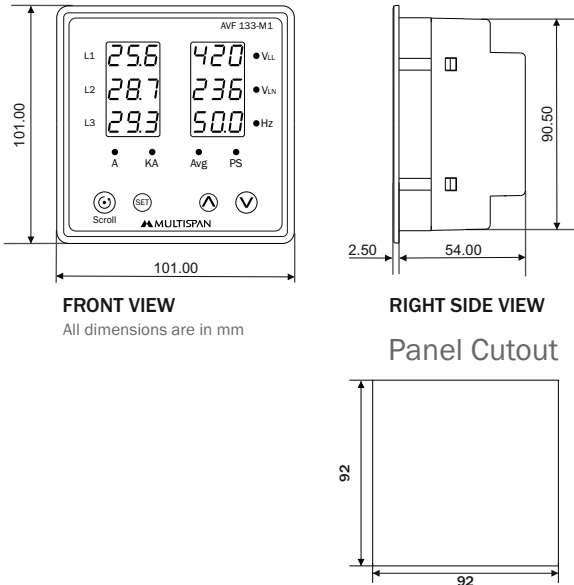

1. Prepare the panel cutout with proper dimensions as show above.
2. Fit the unit into the panel with the help of clamp given.
3. The equipment in its installed state must not come in close proximity to any heating source, caustic vapors, oils steam, or other unwanted process by products.
4. Use the specified size of crimp terminal (M3.5 screws) to wire the terminal block. Tightening the screws on the terminal block using the tightening torque of the range of 0.5 N.m.
5. Do not connect anything to unused terminals.

## WARNING GUIDELINES

**⚡ WARNING : Risk of electric shock.**

1. To prevent the risk of electric shock power supply to the equipment must be kept OFF while doing the wiring arrangement. Do not touch the terminals while power is being supplied.
2. To reduce electromagnetic interference, use wire with adequate rating and twists of the same of equal size shall be made with shortest connection.
3. Cable used for connection to power source, must have a cross section of 1mm<sup>2</sup> or greater. These wires should have insulations capacity made of at least 1.5kV.
4. A better anti-noise effect can be expected by using standard power supply cable for the instrument.

## ! SAFETY PRECAUTION

All safety related codifications, symbols and instructions that appear in this operating manual or on the equipment must be strictly followed to ensure the safety of the operating personnel as well as the instrument.

If all the equipment is not handled in a manner specified by the manufacturer, it might impair the protection provided by the equipment.

Read complete instructions prior to installation and operation of the unit.

**WARNING : Risk of electric shock.**

## MAINTENANCE

1. The equipment should be cleaned regularly to avoid blockage of ventilating parts.
2. Clean the equipment with a clean soft cloth. Do not use isopropyl alcohol or any other cleaning agent.
3. Fusible resistor must not be replaced by operator.

## WIRING DIAGRAM

### 3 Phase - 4Wire

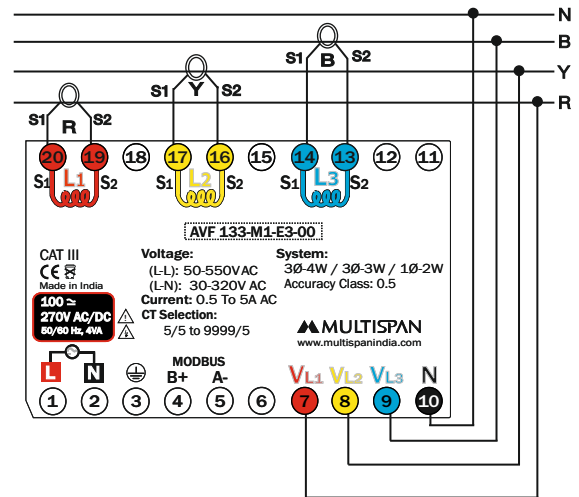

### 3 Phase - 3Wire

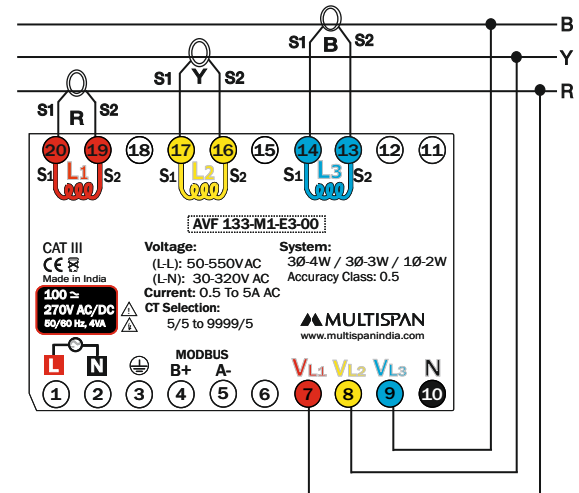

### 1 Phase - 2Wire

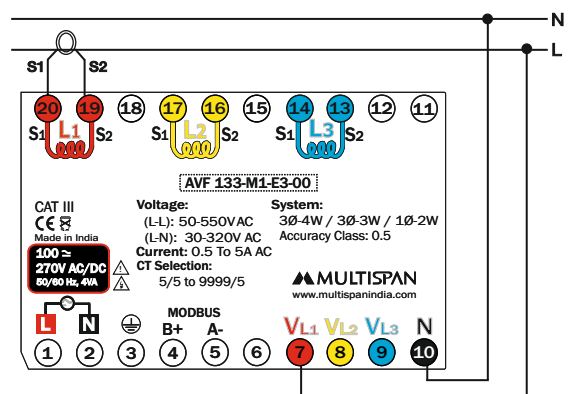

## MODBUS :- AVF-133-M1

Salve Address :	1 to 127
Baudrate :	4800,9600,19200,38400 bps
Parity :	None,Even,Odd
Datatype :	Long,Float (32 Bit Little Endian Byte Swap)
Read Function Register :	0x03 and 0x04
Frame Delay	0 - 99

### Modbus Parameter

Press **SET** key & **^** key together for Modbus Parameter

P A S		
S U O	3 5	Password 35
r d		

↓ Press **SET** key

A d d		
r E S	1	Address 1 - 127

↓ Press **SET** key

b A u		Baudrate
d r A	9 6 0	4800, 9600, 19200, 38400
t E	0	

↓ Press **SET** key

P A r		Parity
i t y	n o n	Non, Even, Odd

↓ Press **SET** key

r d		RDFC
F c	0 3	OX 03, OX 04

↓ Press **SET** key

d A t		Data Type
A t y	F L O	Long, Float
P E	A t	

↓ Press **SET** key

F r i		Delay
d L y	0	0 - 99

↓ Press **SET** key to save & exit

Sr.No	Access Type	Parameter	Register									
			Data Type									
			Float	Long								
1	R	R- Phase Neutral	0	0								
2	R	Y- Phase Neutral	2	2								
3	R	B- Phase Neutral	4	4								
4	R	RYB- Average	6	6								
5	R	RY- Phase to Phase Voltage	8	8								
6	R	YB- Phase to Phase Voltage	10	10								
7	R	BR- Phase to Phase Voltage	12	12								
8	R	Line to Line average Voltage	14	14								
9	R	R - Ampere	16	16								
10	R	R - DP	18	18								
11	R	Y - Ampere	20	20								
12	R	Y - DP	22	22								
13	R	B - Ampere	24	24								
14	R	B - DP	26	26								
15	R	Amp to Average	28	28								
16	R	Average to DP	30	30								
17	R	Frequency	32	32								
18	R	Load Hour	34	34								
19	R	Load Hour per minute	36	36								
20	R	RPM	38	38								
21	R	Phase Sequence Indicate	40	40								
			<table border="1"> <tr><th>Selection</th><th>Value</th></tr> <tr><td>OK Sequence</td><td>0</td></tr> <tr><td>Phase Sequence Relay</td><td>1</td></tr> </table>		Selection	Value	OK Sequence	0	Phase Sequence Relay	1		
Selection	Value											
OK Sequence	0											
Phase Sequence Relay	1											
22	R/W	CT	42	42								
23	R/W	Network Selection	44	44								
			<table border="1"> <tr><th>Selection</th><th>Value</th></tr> <tr><td>3P-3W</td><td>0</td></tr> <tr><td>3P-4W</td><td>1</td></tr> <tr><td>1P-2W</td><td>2</td></tr> </table>		Selection	Value	3P-3W	0	3P-4W	1	1P-2W	2
Selection	Value											
3P-3W	0											
3P-4W	1											
1P-2W	2											
24	R/W	Load Hour	46	46								
			<table border="1"> <tr><th>Selection</th><th>Value</th></tr> <tr><td>Disable</td><td>0</td></tr> <tr><td>Enable</td><td>1</td></tr> </table>		Selection	Value	Disable	0	Enable	1		
Selection	Value											
Disable	0											
Enable	1											
25	R/W	Load Hour %	48	48								
26	R/W	RPM	50	50								
			<table border="1"> <tr><th>Selection</th><th>Value</th></tr> <tr><td>Disable</td><td>0</td></tr> <tr><td>Enable</td><td>1</td></tr> </table>		Selection	Value	Disable	0	Enable	1		
Selection	Value											
Disable	0											
Enable	1											
27	R/W	Pole	52	52								
28	R/W	Scroll & Hold	54	54								
			<table border="1"> <tr><th>Selection</th><th>Value</th></tr> <tr><td>Hold</td><td>0</td></tr> <tr><td>Scroll</td><td>1</td></tr> </table>		Selection	Value	Hold	0	Scroll	1		
Selection	Value											
Hold	0											
Scroll	1											
29	R/W	Load Hour Reset	56	56								

30	R/W	Address	58	58	
31	R/W	Baudrate	60	60	
		Selection			Value
		4800			0
		9600			1
		19200			2
38400	3				
32	R/W	Parity	62	62	
		Selection			Value
		None			0
		Even			1
Odd	2				
33	R/W	RDFC	64	64	
		Selection			Value
		0X 03			0
0X 04	1				
34	R/W	Data Type	66	66	
		Selection			Value
		Long			0
Float	1				
35	R/W	Frame Delay	68	68	