

TECHNICAL SPECIFICATION

Features :

- 24W rated power
- Compact Size
- LED Indicate For Power ON
- Din Rail Mount

Protection Available :

- Overload
- Over short circuit
- Over Temperature

Input Specification :

Supply Voltage	100 to 270V AC±10%,(L-N)
Frequency Range	50 / 60Hz
AC Current (TYP.)	0.450A@100V AC, 0.24A@270V AC
Efficiency (TYP.)	>85%@230V AC
Start UP time	<1 sec@230V AC & <3 sec@100VAC (Full Load)

Output Specification :

Output Voltage	12V DC
Output Current	2A at 12V
Ripple & noise	<1% of V out
Line Regulation	±1%
Load Regulation	±1%
Hold UP Time	<60ms at 230V AC & >15ms at 100V AC (Full Load)

Protection :

Input Fuse	2A -250V AC Internal
Output Over Load	110% of rated Output Current protection Protection Type :Hiccup mode;recover automatically after fault condition is removed
Output Short Circuit	Hiccup mode when output is shorted;Recovers automatically after fault condition is removed.
Over Temperature	Power supply shuts down when the temperature goes above specified limit; Turns on automatically after temperature goes back to Normal operating conditions.
Isolation between Input and Output :	2.5 KV

Physical :

Mounting Type	Din Rail Mount
Size (H x W x D)mm	90 x 22.5 x 75
Material	Polycarbonate (PC)

Environmental :

Working Temperature	-25 °C to 50 °C * De-rate output power at 3w/°C above +50 °C Ambient
Storage Temperature	-40 °C to 85 °C
Relative Humidity	95% RH Non-condensing

CONNECTION DIAGRAM

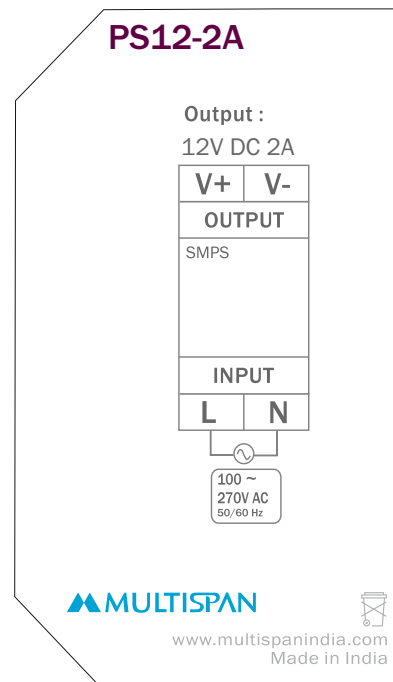

MECHANICAL DIMENSIONS

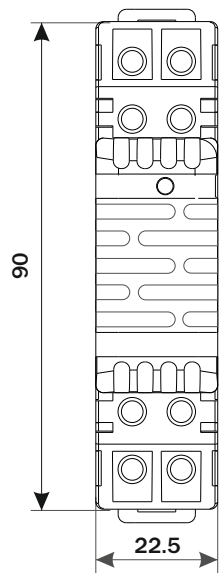

FRONT VIEW

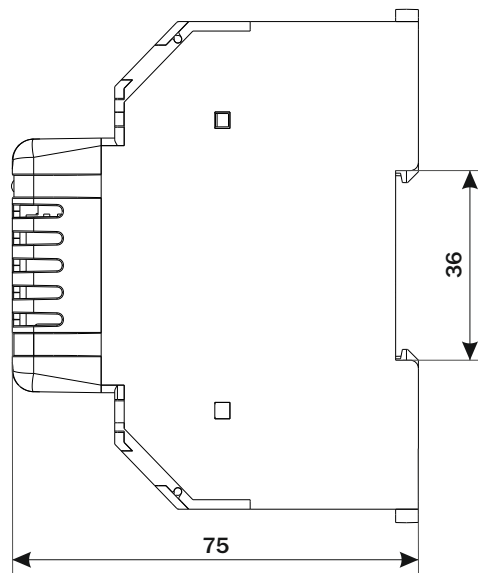

RIGHT SIDE VIEW

All dimensions are in mm

POWER SUPPLY UNIT INSTALLATION STEPS

- Ensure that the power supply is turned off before starting the installation.
- Use a standard 35mm DIN rail channel and make sure that it is securely mounted.
- As per Fig. 1(a), hold the power supply unit at a slight angle and place it over the top edge of the DIN rail channel.
- Press the unit slightly downward until it mounts securely on the DIN rail as per Fig. 1(b).
- To remove the power supply unit, insert a screwdriver into the clamp at the bottom, as per Fig. 2.
- Tilt the power supply unit slightly upward and remove it.

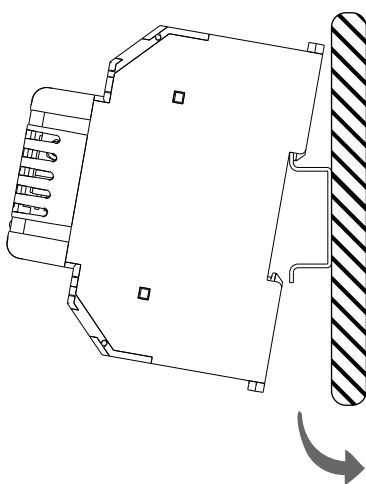
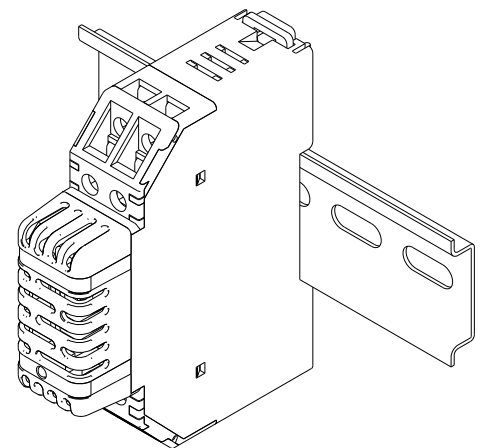

Fig. 1(a)

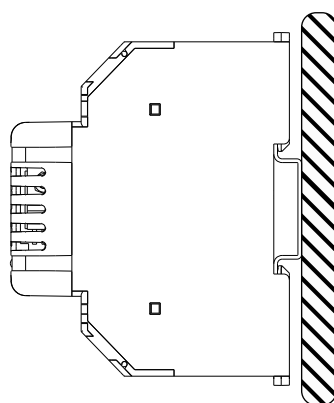

Fig. 1(b)

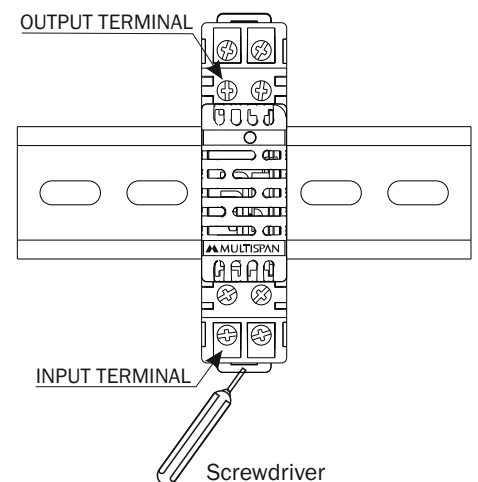

Fig. 2



SAFETY PRECAUTION

All safety related codifications, symbols and instructions that appear in this operating manual or on the equipment must be strictly followed to ensure the safety of the operating personnel as well as the instrument.

If all the equipment is not handled in a manner specified by the manufacturer, it might impair the protection provided by the equipment.



Read complete instructions prior to installation and operation of the unit.



WARNING : Risk of electric shock.

WARNING GUIDELINES



WARNING : Risk of electric shock.

1. To prevent the risk of electric shock, power supply to the equipment must be kept OFF while doing the wiring arrangement. Do not touch the terminals while power is being supplied.
2. To reduce electro magnetic interference, use wire with adequate rating and twists of the same of equal size shall be made with shortest connection.
3. Cable used for connection to power source, must have a cross section of 1mm² or greater. These wires should have insulations capacity made of at least 1.5kV.
4. A better anti-noise effect can be expected by using standard power supply cable for the instrument.

INSTALLATION GUIDELINES

1. This equipment, being built-in-type, normally becomes a part of main control panel and in such case the terminals do not remain accessible to the end user after installation and internal wiring.
2. Do not allow pieces of metal, wire clippings, or fine metallic fillings from installation to enter the product or else it may lead to a safety hazard that may in turn endanger life or cause electrical shock to the operator.
3. Circuit breaker or mains switch must be installed between power source and supply terminal to facilitate power 'ON' or 'OFF' function. However this mains switch or circuit breaker must be installed at convenient place normally accessible to the operator.
4. Use and store the instrument within the specified ambient temperature and humidity ranges as mentioned in this manual.

MECHANICAL INSTALLATION GUIDELINES

1. Fit the unit into the panel with the help of clamp given.
2. The equipment in its installed state must not come in close proximity to any heating source, caustic vapors, oil steam, or other unwanted process By products.
3. Use the specified size of crimp terminal (M3.5 screws) to wire the terminal block. Tightening the screws on the terminal block using the tightening torque of the range of 0.5 N.m.
4. Do not connect anything to unused terminals.

MAINTENANCE

1. The equipment should be cleaned regularly to avoid blockage of ventilating parts.
2. Clean the equipment with a clean soft cloth. Do not use isopropyl alcohol or any other cleaning agent.
3. Fusible resistor must not be replaced by operator.

Specifications are subject to change, since development is a continuous process,
 So for more updated operating information and Support,
 Please contact our Helpline: +91-9978991474/9081078683 or
 Email at service@multispanindia.com Ver:2409