



TECHNICAL SPECIFICATION

FEATURES :

Protection Available	<ul style="list-style-type: none"> Over Voltage Under Voltage Over Frequency Under Frequency Asymmetry Phase Loss Phase Sequence
4 digit bright LED display, Auto/ Manual/ ZVR Reset Option	
Network Selection 3Ø-3W/3Ø-4W/1Ø-2W	
Time parameter: Power on delay, Trip delay Recovery time (Auto Reset)	

INPUT SPECIFICATION :

Direct Voltage AC	50 to 300V AC (L - N) 3Ø-4W/1Ø-2W 85 to 520V AC (L - L) 3Ø-3W
Frequency	45.0 Hz to 65.0 Hz
Resolution	1 Volt

DISPLAY AND KEY :

Display	Upper: 3 digit, 7 segment, 0.63" Lower: 3 digit, 7 segment, 0.30"
Keys	SET/ENT, INC, DEC/RESET

GENERAL SPECIFICATION :

Dimension (mm)	72 (H) x 72 (W) x 45 (D) mm
Panel Cutout	68 (H) x 68 (W) mm
Trip Setting	Under Voltage : 85-520V AC 3Ø-3W 50-300V AC 3Ø-4W/1Ø-2W Over Voltage : 85-550V AC 3Ø-3W 50-330V AC 3Ø4W/1Ø2W Under Frequency : 45.0 Hz To 65.0 Hz Over Frequency : 45.0 Hz To 65.0 Hz Phase Asymmetry : 2-30%
Time Parameter	Power ON Delay Time : 0 To 99 Sec. Trip delay Time : 0 To 999 Sec. Recovery Time : 0 To 99 Sec.

ACCURACY

Class 1.0 (Standard)

OUTPUT SPECIFICATION :

Relay	2 nos.
Relay Type	1 C/O (NO-C-NC)
Rating	1 st Relay 10A, 230V AC 2 nd Relay 5A, 230V AC

AUXILIARY SUPPLY :

Supply voltage	50 to 520V AC,50Hz
Power consumption (VA RATING)	4VA

ENVIRONMENT CONDITION :

Operating Temp.	0°C to 55°C
Relative Humidity	UP to 95% RH (non-condensing)
Protection Level (As per request)	IP-65 (Front side) As per IS/IEC 60529 : 2001

NETWORK CONNECTION :

3Ø-3W/3Ø-4W/1Ø-2W

MECHANICAL INSTALLATION

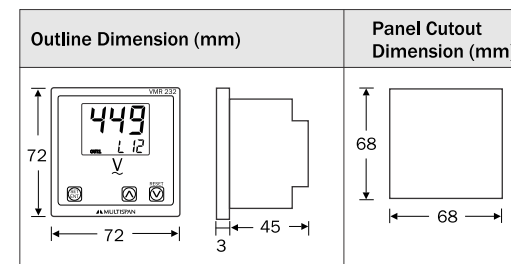

TERMINAL CONNECTION

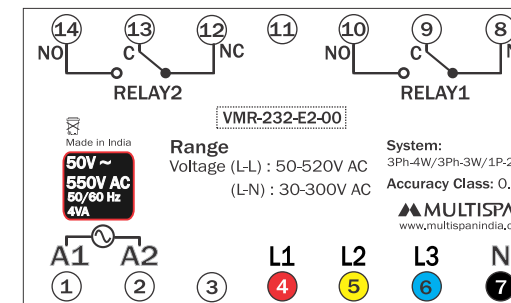

KEY OPERATION

FUNCTION	PRESS KEY
OPERATOR MODE	
To enter in parameter setting	SET ENT For 5 sec
To view individual phase voltage	▲ OR ▼
To Scroll & Hold Page	SET ENT + ▲
To reset the relay contact in manual mode after tripping	▼ RST
PARAMETER SETTING MODE	
It is used to set parameter value and to be save & exit from menu	SET ENT
To increment value in parameter setting	▲
To decrement value in parameter setting	▼ RST

DISPLAY PAGE

3Ø-4W	3Ø-3W	1Ø-2W
1) Voltage L1-N 240 L1	1) Voltage L1-L2 415 L12	1) Voltage L1-N 240 L1
2) Voltage L2-N 241 L2	2) Voltage L2-L3 416 L23	2) Frequency 500 H2
3) Voltage L3-N 250 L3	3) Voltage L3-L1 420 L31	
4) Frequency 500 H2	4) Frequency 500 H2	

MECHANICAL INSTALLATION

1. Prepare the panel cutout with proper dimensions as shown above.
2. Fit the unit into the panel with the help of clamp given.
3. The equipment in its installed state must not come in close proximity to any heating source, caustic vapors, oil steam, or other unwanted process byproducts.
4. Use the specified size of crimp terminal (M3.5 screws) to wire the terminal block. Tightening the screws on the terminal block using the tightening torque of the range of 1.2 N.m.
5. Do not connect anything to unused terminals.

MAINTENANCE

- 1) The equipment should be cleaned regularly to avoid blockage of ventilating parts.
- 2) Clean the equipment with a clean soft cloth. Do not use isopropyl alcohol or any other cleaning agent.
- 3) Fusible resistor must not be replaced by operator.

INSTALLATION GUIDELINES

- 1) Do not allow pieces of metal, wire clippings, or fine metallic fillings from installation to enter the product or else it may lead to a safety hazard that may in turn endanger life or cause electrical shock to the operator.
- 2) Circuit breaker or mains switch must be installed between power source and supply terminal to facilitate power 'ON' or 'OFF' function. However this mains switch or circuit breaker must be installed at convenient place normally accessible to the operator.
- 3) Use and store the instrument within the specified ambient temperature and humidity ranges as mentioned in this manual.



SAFETY PRECAUTION

All safety related codifications, symbols and instructions that appear in this operating manual or on the equipment must be strictly followed to ensure the safety of the operating personnel as well as the instrument.

If all the equipment is not handled in a manner specified by the manufacturer, it might impair the protection provided by the equipment.



Read complete instructions prior to installation and operation of the unit.



WARNING : Risk of electric shock.

WARNING GUIDELINES



WARNING : Risk of electric shock.

- 1) To prevent the risk of electric shock, power supply to the equipment must be kept OFF while doing the wiring arrangement. Do not touch the terminals while power is being supplied.
- 2) To reduce electro magnetic interference, use wire with adequate rating and twists of the same of equal size shall be made with shortest connection.
3. Cable used for connection to power source, must have a cross section of 1mm or greater. These wires should have insulations capacity made of at least 1.5kV.
- 4) A better anti-noise effect can be expected by using standard power supply cable for the instrument.

PARAMETER SETTING

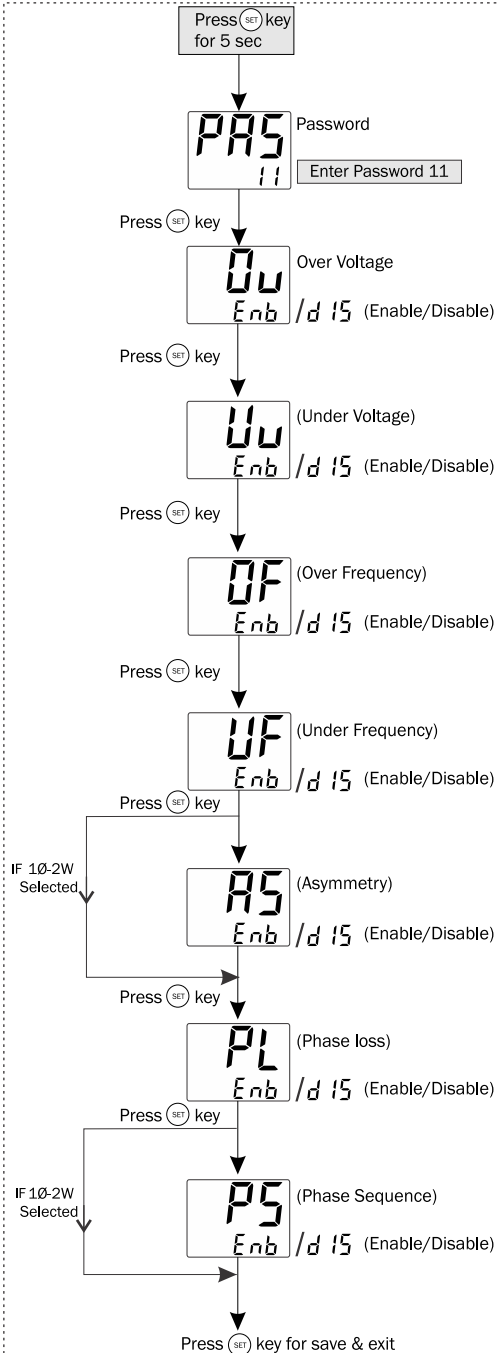

Password 11 : To Enable / Disable parameter (Over Voltage, Under Voltage, over Frequency, Under Frequency, Asymmetry, Phase loss, Phase sequence)

Password 37 : To set Power on delay time, Trip delay Time, Relay Fault Mode, Reset mode, network selection

Password 73 : Relay-1 setting .

Password 97 : Relay-2 setting .

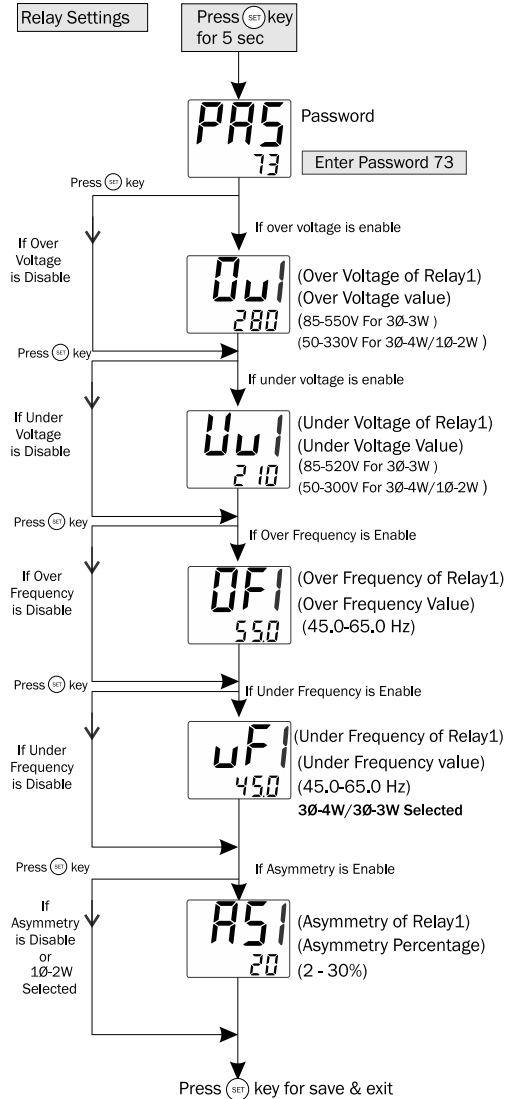

NOTE :-

- If R2M (Relay-2 mode) is selected as R1 (Relay-1), all the setting done for Relay-1 will be automatically set for Relay-2.
- If Reset Mode Selected As ZVR (Zero Value Reset), then the Relay will be reset after Selected Reset time once the healthy condition achieved OR Zero Value reached.

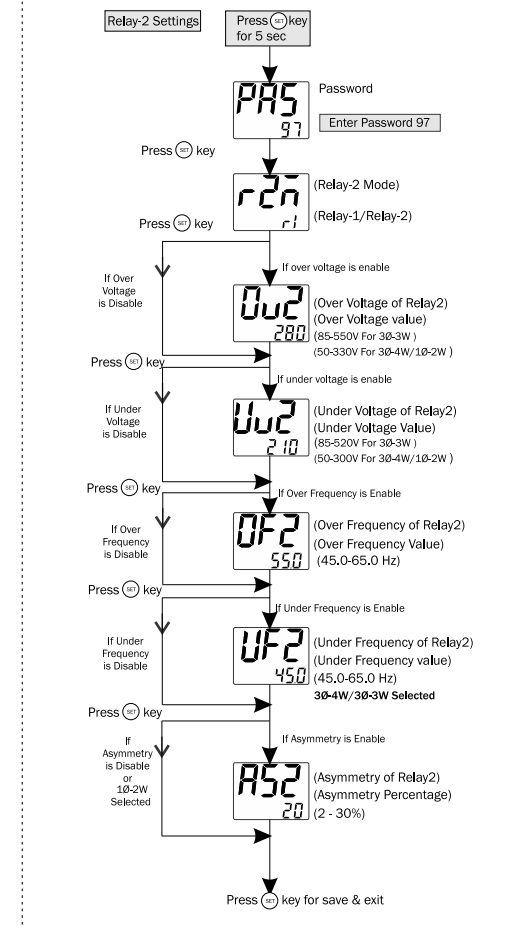
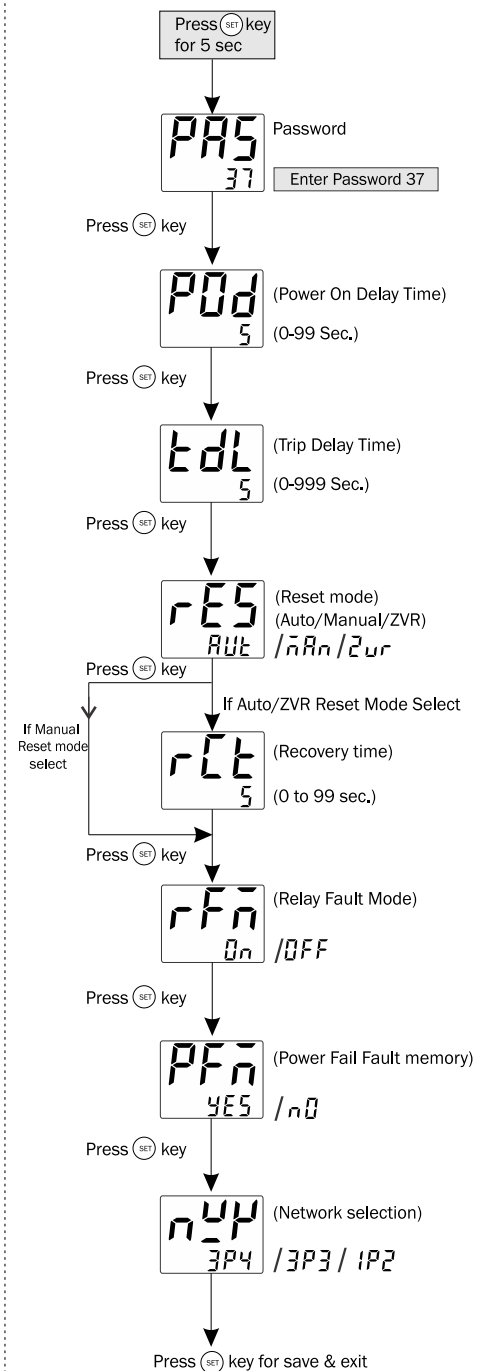

FAULT MESSAGE

Ov 400	<ul style="list-style-type: none"> Over Voltage fault V_{L1L2}(3Ø-3W) or V_{L1}(3Ø-4W) Over Voltage Value=400.6V
UF 49.5	<ul style="list-style-type: none"> Under Frequency Fault Under Frequency Value=49.5 Hz
AS 20	<ul style="list-style-type: none"> Asymmetry Voltage between y & B Phase Asymmetry Percentage = 20 %
PL	<ul style="list-style-type: none"> L1 - Phase loss
PS	<ul style="list-style-type: none"> Phase sequence Fault

Specifications are subject to change, since development is a continuous process. So for more updated operating information and Support, Please contact our Helpline: +91-9081078683/81 or Email at service@multispanindia.com Ver:191201