

Technical Specification

Model	MDT-4310N
Display	3 Digit 7 seg 0.56",LED Display
Size (mm)	48 (H) X 48 (W) X 70 (D) mm
Panel Cutout	44 X 44 mm
Range	Multi Range
Power Supply	100 to 270V AC,50/60 Hz, Approx 3VA
Input	Start Pulse M/S
Reset	Front & back key
Output	1 Relay 1C/O,5A,230V AC
Protection Level (As per request)	IP-65 (Front side) As per IS/IEC 60529 : 2001
Operating Temperature	0°C To 55°C
Relative Humidity	Up to 95% RH Non Condition

Working

- 1). Turn on the instrument. Set time through thumbwheel according to your requirement.
- 2). To start the timer with power on short terminal no. 6 & 7.
- 3). To reset timer, press front reset key on short reset terminal no. 7 & 8.

Note :-

Parameter setting is done by using Left First thumb wheel and reset key.:

1. Left first thumbwheel is used to change parameter
2. Reset key is used to change parameter value

Parameter setting:

1. For parameter setting, Press reset key then power on, display will show by default Parameter.

Connection Diagram

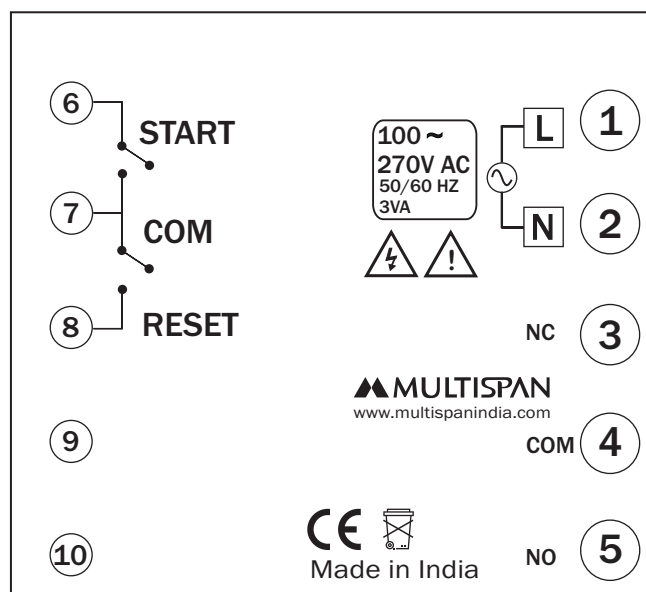

**Thumbwheel
Switch Position**

Reset Key + Power ON



100	Time unit (Sec,Min,Hour) (Press reset key to change parameter value)
200	Time Range: (999,99.9,9.99 For Sec.) (999,99.9 For Min.) (999,99.9 For Hour.) (Press reset key to change parameter value)
300	Operating Relay Mode (Delayed ON, Delayed OFF) (Press reset key to change parameter value)
400	Counting Direction (UP Or DOWN) (Press reset key to change parameter value)
500	Memory (YES Or NO) (Press reset key to change parameter value)
600	Auto Manual Mode (IF Time = 0 then manual mode is selected IF Time = 0 (Range 1 - 99 SEC.) then auto mode selected) (Press reset key to change parameter value)
700 800 900 000	OUT



Press reset key to Save & Exit

Safety Precautions

All safety related codifications, symbols and instructions that appear in this operating manual or on the equipment must be strictly followed to ensure the safety of the operating personnel as well as the instrument.

If all the equipment is not handled in a manner specified by the manufacturer, it might impair the protection provided by the equipment .

=> Read complete instructions prior to installation and operation of the unit.

 **WARNING** : Risk of electric shock.

Warning Guidelines

- 1) To prevent the risk of electric shock power supply to the equipment must be kept OFF while doing the wiring arrangement. Do not touch the terminals while power is being supplied.
- 2) To reduce electro magnetic interference, use wire with adequate rating and twists of the same of equal size shall be made with shortest connection.
- 3) Cable used for connection to power source, must have a cross section of 1mm^2 or greater. These wires should have insulations capacity made of at least 1.5kV.
- 4) A better anti-noise effect can be expected by using standard power supply cable for the instrument.

Installation Guidelines

- 1) This equipment, being built-in-type, normally becomes a part of main control panel and such in case the terminals do not remain accessible to the end user after installation and internal wiring.
- 2) Do not allow pieces of metal, wire clippings, or fine metallic fillings from installation to enter the product or else it may lead to a safety hazard that may in turn endanger life or cause electrical shock to the operator.
- 3) Circuit breaker or mains switch must be installed between power source and supply terminal to facilitate power 'ON' or 'OFF' function. However this mains switch or circuit breaker must be installed at convenient place normally accessible to the operator.
- 4) Use and store the instrument within the specified ambient temperature and humidity ranges as mentioned in this manual.

Mechanical Installation

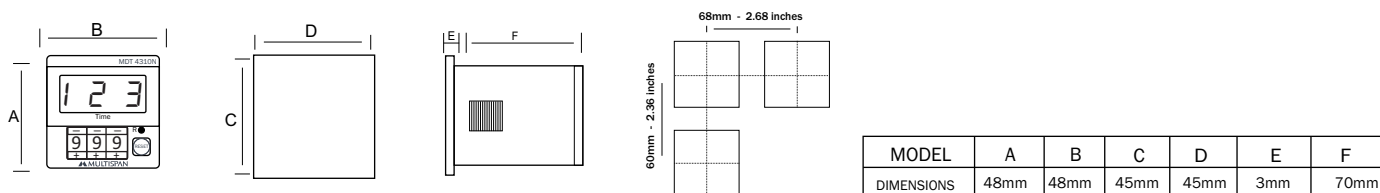

- 1) Prepare the panel cutout with proper dimensions as show above.
- 2) Fit the unit into the panel with the help of clamp given.
- 3) The equipment in its installed state must not come in close proximity to any heating source, caustic vapors, oils steam, or other unwanted process by products.
- 4) Use the specified size of crimp terminal (M3.5 screws) to wire the terminal block. Tightening the screws on the terminal block using the tightening torque of the range of 1.2 N.m.
- 5) Do not connect anything to unused terminals.

Maintenance

- 1) The equipment should be cleaned regularly to avoid blockage of ventilating parts.
- 2) Clean the equipment with a clean soft cloth. Do not use isopropyl alcohol or any other cleaning agent.
- 3) Fusible resistor must not be replaced by operator.

Product improvement and upgrade is a constant procedure. So for more updated operating information and Support, Please contact our Helpline: +91-9081078681/83 or Email at service@multispanindia.com Ver: 2102