

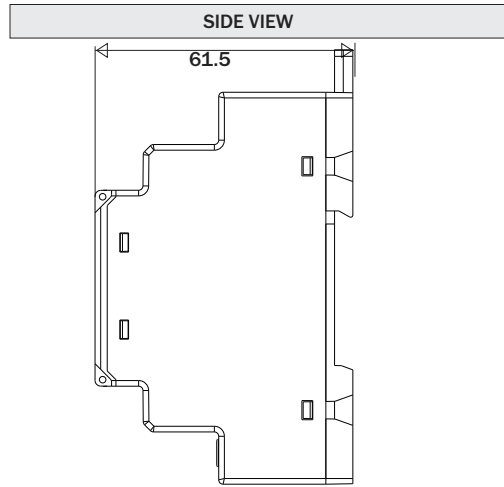

MECHANICAL DIMENSION

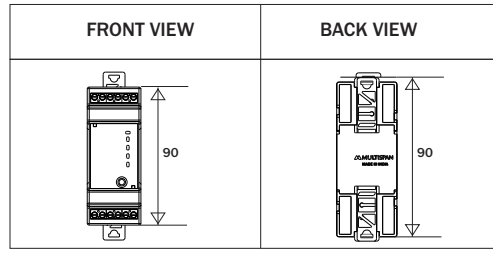

TERMINAL CONNECTION

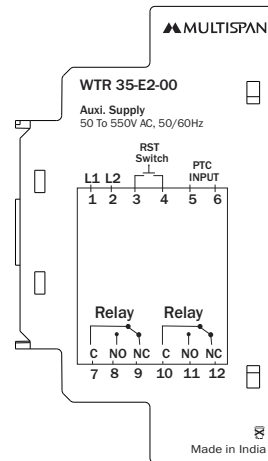

TRIP SETTING

1) You can use any PTC (Thermistor) with the desired Normal response Temperature (NRT) value ranging between 70 °C to 180 °C e.g. if you intend to control the Temperature above 80 °C then select PTCs with 80 °C NRT. Your WTR35 deactuates the relay output contact at NRT+5 °C of the PTC (Thermistor) in use. Please see for PTC chart. You WTR35 is factory set to actuate the at relay at the total loop resistance of the series connected thermistors of 4Kohms and above at NTR value.

TRIP TIME DELAY

You WTR35 trip instaneously (Less than 1 sec) at NTR +5 °C

RESETTING : ( AUTO / MANUAL / REMOTE )

In Auto mode WTR35 will reset automatically when the total loop resistance of series connected thermistors droop below 1.65Kohms ±10%. In manual mode user should reset the unit by pressing front push button between terminal 3 and 4, BUT while using remote reset, just press the external push button and quickly release it, otherwise unit will entr in programming mode

INPUT SENSORE :

You S2 WTR1 is suitable for Positive Temperature coefficient Thermistors with the typical characteristic as shown in figure. The Thermistors are to be connected in series only. You may use either single Thermistor or max.3 Thermistors provided the total loop resistance of such series connected to Thermistor does not exceeas 1.65 Kohms at 25 °C temperature. The Thermistor are to be embedded at the hot spot locations in the motor windings.

MOUNTING :

The WTR35 is suitable for 35mm DIN RAIL mounting.

TECHNICAL SPECIFICATION

INPUT SPECIFICATION :

Auxiliary Supply	50 To 550V AC 50/60Hz
Output contact	1Relay 2 CO
contact rating(resistive)	5 Amp 230V AC (resistive)
Input	PTC Thermistor
Setting for PTC	
1. Sensor Short	0-39 ohm
2. Sensor Healthy	40 ohm - 4K ohm
3. Sensor Trip	4.1K ohm - 5.5K ohm
4. Sensor Open	5.6K ohm & Above
5. Sensor Cut in	1.5K ohm - 1.8K ohm
Temperature range for Thermistor	70 °C to 180 °C ( for PTC)
Trip time delay	Less than 1 sec.
Resetting	Auto / Manual(Remote)
Mode of operation	Fail safe / Non-fail safe
Indications:	
1. Power on	LED
2. Sensor Short	LED
3. Sensor Healthy	LED
4. Sensor Trip	LED
5. Sensor Open	Sensor Short, Healthy & Trip LED Blink
Enclosure	ABS / PC ABS
Dimensions (mm)	90 X 35 X 61.5
Mounting	35 mm Rail Mounting
Indications:	
1. Power on	-5 °C to +60 °C
2. Sensor faulty/Healthy	Up to 95% Rh

ELECTRICAL CONNECTIONS :

See figure 1 for electrical connection details of S2 WTR1.

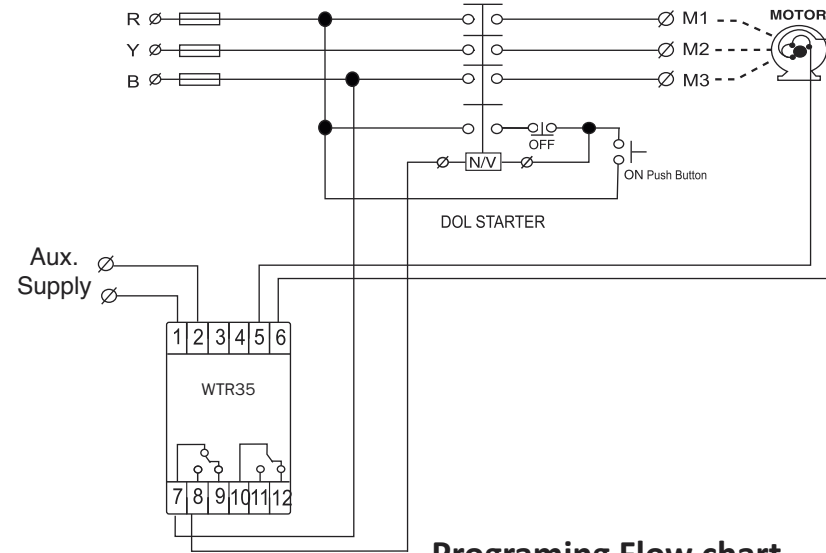

Programing Flow chart

		Press reset 'RST' key then power on.
≥5 sec.	Short LED ☆ 'Blink'	Entered in programing mode (Auto / Manual / Reset Selection)
1>to>2 sec.	○ 'ON'	Auto reset mode
1>to>2 sec.	● 'OFF'	Manual reset mode
≥5 sec.	Healthy LED ☆ 'Blink'	Fail sate / Non-fail sate mode Selection
1>to>2 sec.	'ON'	Fail sate mode
1>to>2 sec.	● 'OFF'	Non Fail sate mode
≥5 sec.	Trip LED ☆ 'Blink'	Relay testing mode
1>to>2 sec.	○ 'ON'	Relay on
1>to>2 sec.	● 'OFF'	Relay off
	☆ ' Slow Blink'	Auto exit and power off
☆ - Fast flase      ● - Fast flase      ☆ - ' Slow Blink'      ○ - ON		

## NOTE :

### To Configure fault type 'NO' or 'NC'

- 1) Press reset key then power on instrument , Reset key pressed continuously up to 5 Second.
- 2) If front relay indication is ' ON 'Means relay is 'NC' in healthy condition.
- 3) One can change by pressing 'TEST' key , If front relay indication is 'OFF' means relay is 'NO' in healthy condition.

### MAINTENANCE

- 1) The equipment should be cleaned regularly to avoid blockage of ventilating parts.
- 2) Clean the equipment with a clean soft cloth. Do not use isopropyl alcohol or any other cleaning agent.
- 3) Fusible resistor must not be replaced by operator.



### SAFETY PRECAUTION

All safety related codifications, symbols and instructions that appear in this operating manual or on the equipment must be strictly followed to ensure the safety of the operating personnel as well as the instrument.

If all the equipment is not handled in a manner specified by the manufacturer, it might impair the protection provided by the equipment.



Read complete instructions prior to installation and operation of the unit.



**WARNING :** Risk of electric shock.

### WARNING GUIDELINES



**WARNING :** Risk of electric shock.

- 1) To prevent the risk of electric shock, power supply to the equipment must be kept OFF while doing the wiring arrangement. Do not touch the terminals while power is being supplied.
- 2) To reduce electro magnetic interference, use wire with adequate rating and twists of the same of equal size shall be made with shortest connection.
- 3). Cable used for connection to power source, must have a cross section of 1mm or greater. These wires should have insulations capacity made of at least 1.5kV.

### INSTALLATION GUIDELINES

- 1) Do not allow pieces of metal, wire clippings, or fine metallic fillings from installation to enter the product or else it may lead to a safety hazard that may in turn endanger life or cause electrical shock to the operator.
- 2) Circuit breaker or mains switch must be installed between power source and supply terminal to facilitate power 'ON' or 'OFF' function. However this mains switch or circuit breaker must be installed at convenient place normally accessible to the operator.
- 3) Use and store the instrument within the specified ambient temperature and humidity ranges as mentioned in this manual.

### MECHANICAL INSTALLATION

- 1) To install the instrument on a DIN rail, raise the clamp at the back of the instrument and place it on the rail. Now release the clamp, so the instrument fits on the DIN rail.
- 2) Ensure proper fitting of the instrument by pulling it outwards.
- 3) To remove the instrument raise the clamp to release it from the DIN rail.
- 4) The equipment in its installed state must not come in close proximity to any heating source, caustic vapors, oil steam, or other unwanted process byproducts.
- 5) Do not connect anything to unused terminals.