

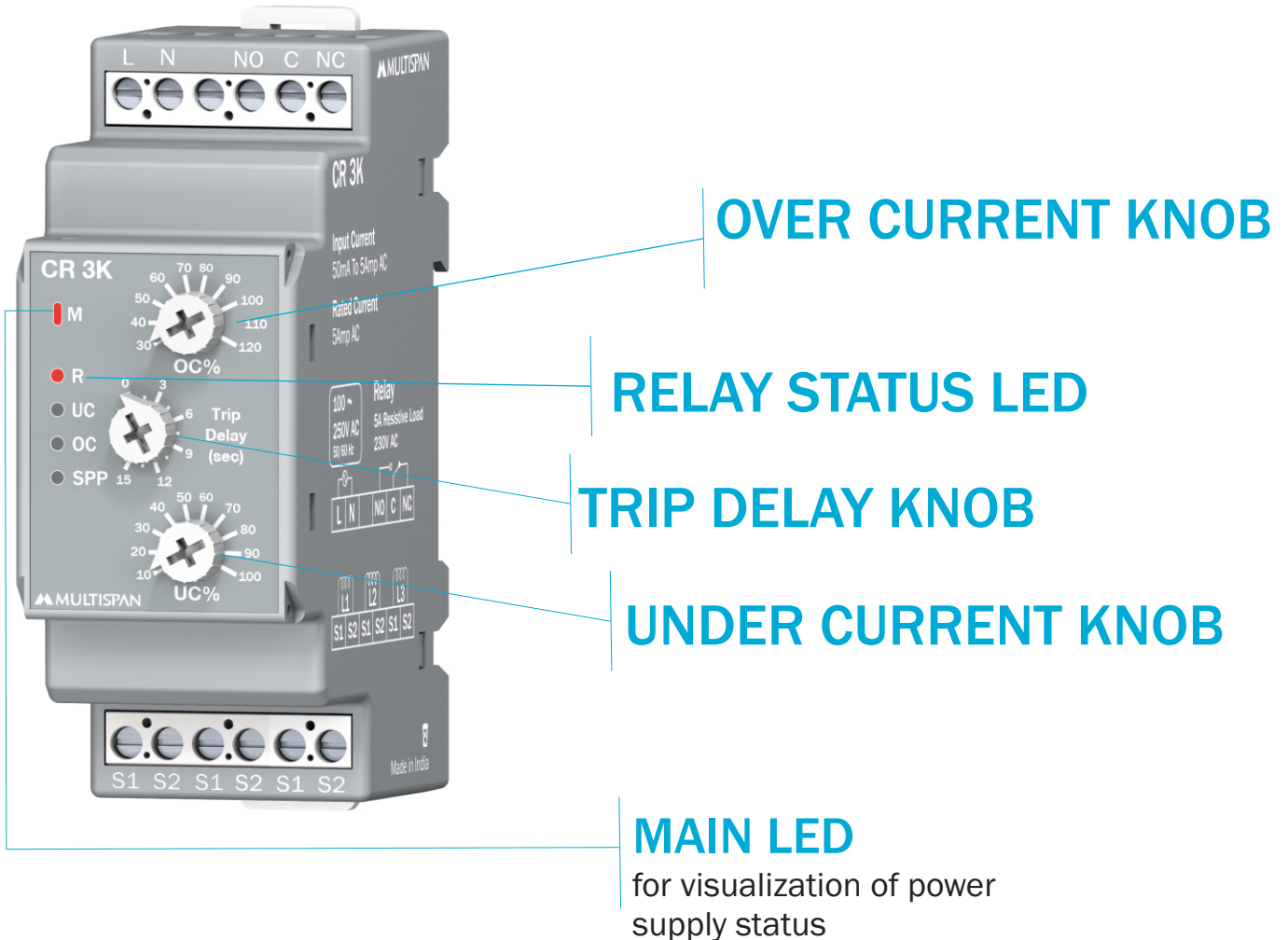

## Current Protection Relay

CR-3K



**Power Supply :** 100-250V AC



**Input Current :** 200mA to 5Amp AC

**Rated Current :** 5A



**Output:** 1 Relay 1C/O ,5A, 230V AC Resistive load



**Tripping Parameters :** Under current  
Over current  
SPP (Single Phase Prevention)

**RESET MODE :** ZVR (ZERO VALUE RESET)

# Terminal Connection:

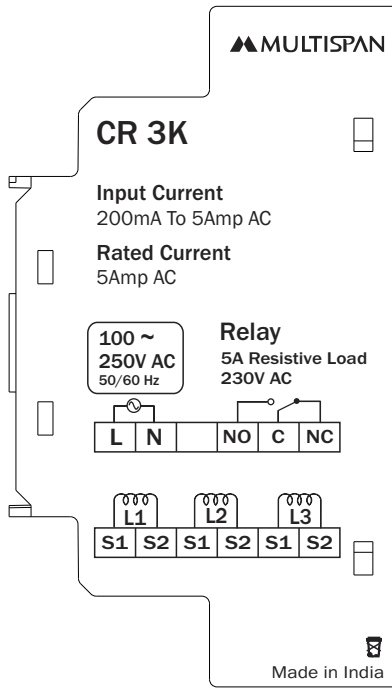

## Delay Time :

Power ON : 2 Sec

Initial Delay : 5 Sec

Recovery Time : 5 Sec

Trip Delay : 0 To 15 Sec Selectable

## LED Indication:

OC - Over current

UC - Under current

SPP - Single Phase Prevention

R - Relay

# Control Function

## Under Current

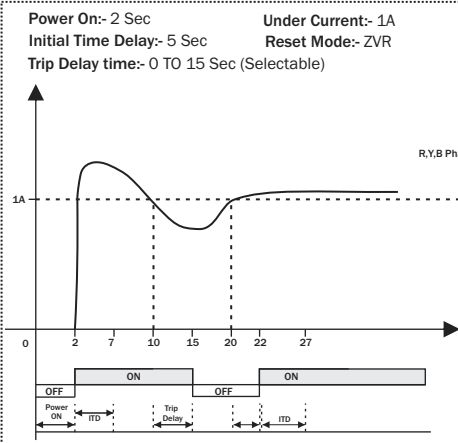

## Over Current

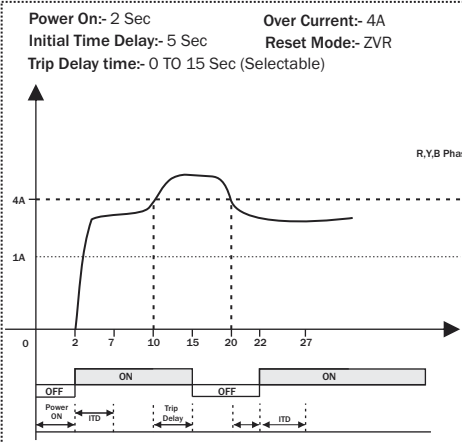

## Single Phase Prevention (SPP)

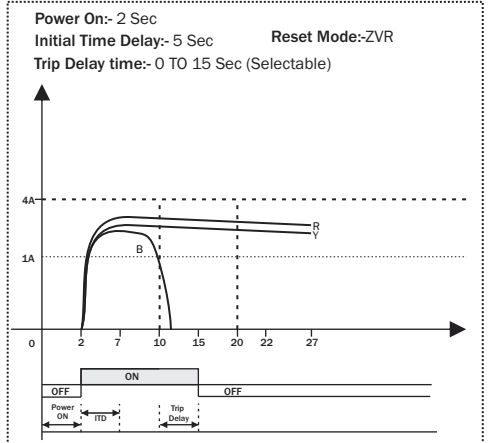

$T_P$  = Power ON Delay (2 Sec)

$ITD$  = Initial Delay Time (5 Sec)

$T$  = Trip Delay (0 TO 15 Sec Selectable )

$RT$  = Recovery Time (5 Sec)

## Dimension

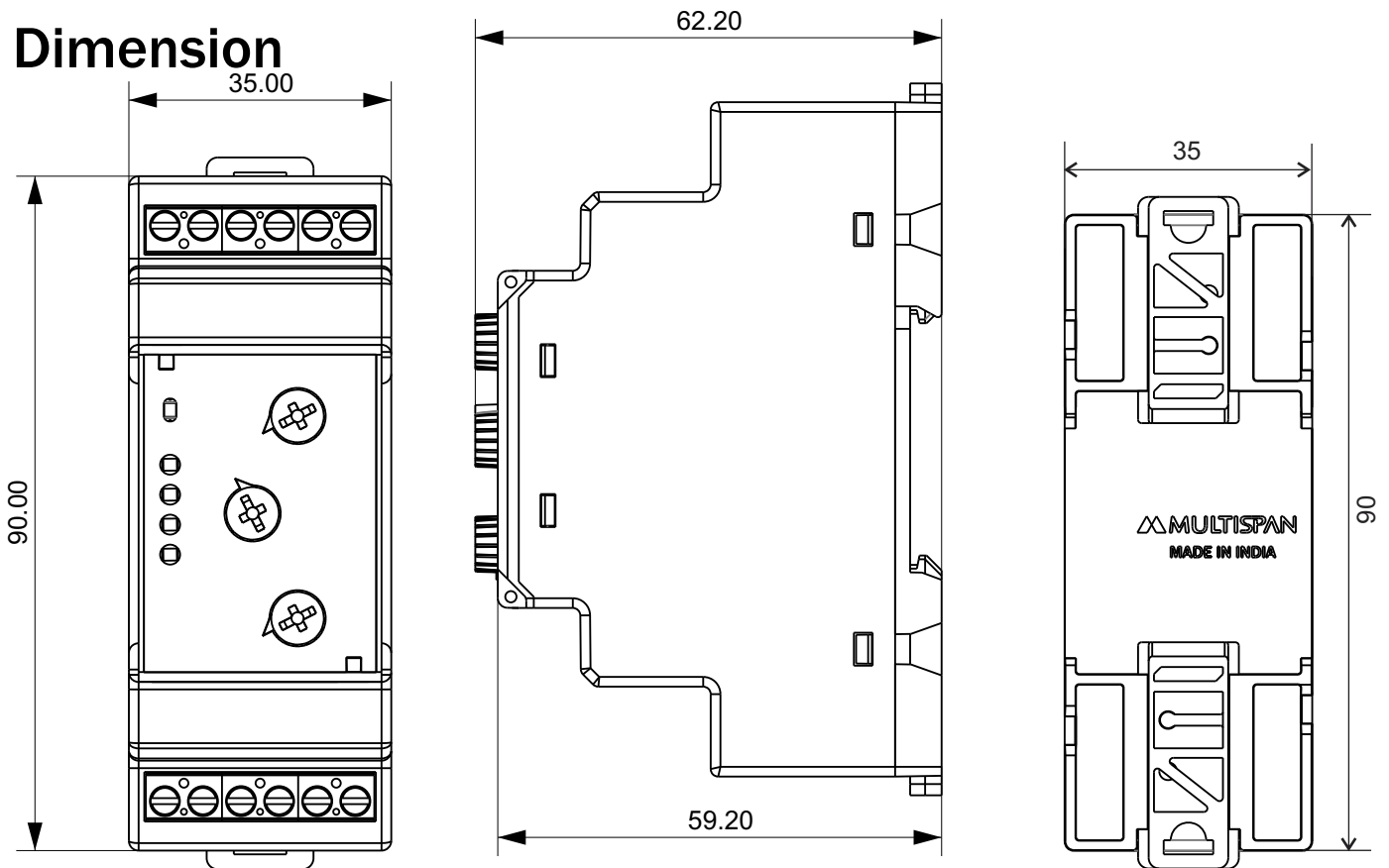

## SAFETY PRECAUTION

All safety related codifications, symbols and instructions that appear in this operating manual or on the equipment must be strictly followed to ensure the safety of the operating personnel as well as the instrument.

If all the equipment is not handled in a manner specified by the manufacturer, it might impair the protection provided by the equipment.



Read complete instructions prior to installation and operation of the unit.



**WARNING** : Risk of electric shock.

## WARNING GUIDELINES



**WARNING** : Risk of electric shock.

1. To prevent the risk of electric shock, power supply to the equipment must be kept OFF while doing the wiring arrangement. Do not touch the terminals while power is being supplied.
2. To reduce electromagnetic interference, use wire with adequate rating and twists of the same of equal size shall be made with shortest connection.
3. Cable used for connection to power source, must have a cross section of  $1\text{mm}^2$  or greater. These wires should have insulations capacity made of at least 1.5kV.
4. A better anti-noise effect can be expected by using standard power supply cable for the instrument.

# INSTALLATION GUIDELINES

1. This equipment, being built-in-type, normally becomes a part of main control panel and in such case the terminals do not remain accessible to the end user after installation and internal wiring.
2. Do not allow pieces of metal, wire clippings, or fine metallic fillings from installation to enter the product or else it may lead to a safety hazard that may in turn endanger life or cause electrical shock to the operator.
3. Circuit breaker or mains switch must be installed between power source and supply terminal to facilitate power 'ON' or 'OFF' function. However this mains switch or circuit breaker must be installed at convenient place normally accessible to the operator.
4. Use and store the instrument within the specified ambient temperature and humidity ranges as mentioned in this manual.

## MECHANICAL INSTALLATION GUIDELINES

- 1) To install the instrument on a DIN rail, raise the clamp at the back of the instrument and place it on the rail. Now release the clamp, so the instrument fits on the DIN rail.
- 2) Ensure proper fitting of the instrument by pulling it outwards.
- 3) To remove the instrument raise the clamp to release it from the DIN rail.
- 4) The equipment in its installed state must not come in close proximity to any heating source, caustic vapors, oil steam, or other unwanted process byproducts.
- 5) Do not connect anything to unused terminals.

Multispan reserves the right to change specifications without prior notice. Printing and typographical errors reserved. Product improvement and upgrade is a constant procedure.

### **Multispan Control Instruments Pvt. Ltd.**

72/B, Phase 1, GIDC Estate, Vatva, Ahmedabad-382445, Gujarat, India.

☎ +91-9978991476/9978991474/9978991482

✉ Service@multispanindia.com

Follow us



www.multispanindia.com